



System for powering autonomous solar cookers by batteries

A. Lamkaddem^a, N. EL Moussaoui^a, M. Rhiat^a, R. Malek^a, K. Kassmi^{a,c,*},
O. Deblecker^b, N. Bachiri^c

^a Mohamed First University, Faculty of Science, Department of Physics, Laboratory of Electromagnetic, Signal Processing & Renewable Energy LESPREE, Team Electronic Materials & Renewable Energy EMRE, Oujda, Morocco

^b University of Mons, Faculty of Engineering - Electrical Power Engineering Unit, Mons, Belgium

^c Association Humain and Environnement of Berkane (AHEB), Berkane, Morocco



ARTICLE INFO

Article history:

Received 24 May 2022

Revised 23 August 2022

Accepted 24 August 2022

Editor: DR B Gyampoh

Keywords:

Photovoltaic renewable energy
Innovative photovoltaic solar cooker
Battery powered solar cooker
DC/DC converter
Efficiency
Control and regulation
optimization

ABSTRACT

In this paper, we propose innovative autonomous solar cookers (hot plates and box ovens) supplied by batteries. The electrical energy is produced by photovoltaic panels (PV) and stored in a battery (24 V, 520 Ah). Hence, the cookers are powered through a Direct Current /Direct Current (DC/DC) boost converter (400 W) composed of three identical cells in parallel. The power switches are controlled by a digital circuit that generates three Pulse Width Modulation (PWM) signals at 20 kHz with an adjustable duty cycle α . The experimental results show that, for electrical power of 375 W and a duty cycle $\alpha = 0.7$, the average inductor current of each cell is equal to 3.8 A. Moreover, the DC voltages and currents at the input/output terminals of the converter are worth 24 V / 11.5 A, and 75 V / and 5 A, respectively. Under these conditions, the efficiency of the power supply system used in the cookers is of the order of 90% and the temperature of their thermal resistors reaches 700 °C. All the electrical quantities are in accordance with the results obtained through simulation using the Orcad Pspice environment. These innovative cookers including hot plates and box ovens are tested experimentally in different cases: heating one liter of water, cooking food (1 kg of fries), and baking bread. The obtained heating times are about 25 min, 20 min, and 30 min, respectively. Moreover, according to which cooking case, the “consumed” battery capacity is worth 4.2% - 5.52% of the capacity of the fully charged battery. All these results show, on the one hand, the proper operation of the three-cell DC/DC boost converter powered by batteries, and, on the other hand, the feasibility of heating water and cooking food using the autonomous solar cookers proposed in this work.

© 2022 The Author(s). Published by Elsevier B.V. on behalf of African Institute of Mathematical Sciences / Next Einstein Initiative.

This is an open access article under the CC BY license (<http://creativecommons.org/licenses/by/4.0/>)

Introduction

In the last decade, half of the meals of the 6 billion inhabitants of the Earth were cooked every day over a wood fire [1,2]. This method of cooking is responsible for serious environmental and ecological problems such as, e.g., deforestation or soil erosion. It also leads to the emission of greenhouse gasses into the atmosphere [1–7] and may cause health problems,

* Corresponding author

E-mail address: k.kassmi@ump.ac.ma (K. Kassmi).

such as burns, eye disorders, and lung diseases [2]. Currently, government guidelines in most countries and the activities of non-governmental organizations (NGOs) are moving towards the use of solar energy, especially in the areas with a high level of sunshine over the year (Africa, Latin America, etc.) [2,8,9]. Ovens powered by with solar thermal energy and located outside homes have been proposed in [4–6]. However, due to their limited performance (heating temperature less than 140 °C), the available cooking modes do not meet users' needs, in particular during periods of low sunlight and at night. Therefore, a sustainable and effective cooker alternative is required that can be used inside and outside homes [10–12], all day long and at night, whatever the period of the year.

In this context and motivated by the decline in world prices for photovoltaic (PV) panels (less than \$0.56 per installed kilowatt peak), a lot of research is being carried out on autonomous cookers powered by photovoltaic solar energy [12,16,17, 26–28]. The present contribution targets the implementation of innovative systems for cooking during the day while storing electrical energy in a battery in anticipation of periods of lower sunlight and nights [9,13,14]. In literature, the main works concern:

- ✓ A box-type solar PV cooker powered by a 60 Ah battery that can heat a volume of water from 30 °C to its boiling point of 100 °C in 105 min [12]. The batteries are charged directly by 200 W peak PV panels.
- ✓ A hybrid box-type solar cooker powered by thermal energy and PV panels of 75 W peak [13,14,30]. These PV panels are used to charge a battery of 45 Ah. The operation of such a cooker supplied by the batteries shows that the boiling of water is reached (at 90 °C) after 80 min, during a day of maximum sunshine of 836 W/m² [13,14].
- ✓ A solar PV-T cooker is formed mainly by [15] a photovoltaic panel and parabolic reflector. The concentrator is employed to concentrate the sun rays and heat an absorbent plate placed inside the box oven. Heating is carried out by the direct supply of the cooker by the electrical energy stored in the batteries. With this type of cooker (using reflectors and photovoltaic energy) the maximum temperature reached after 250 min of operation is approximately equal to 160 °C.
- ✓ A PV cooker without energy storage, consisting of two PV panels (460 W peak), two DC/DC boost converters, and a thermal resistor of 14 Ω [16]. The operation of this innovative cooker, under an illumination varying from 630 W/m² to 730 W/m² and an ambient temperature ranging from 14 °C to 24 °C, allows reaching temperatures of the heating resistor and oil respectively to 580 °C and 265 °C after 30 min.

All work in the literature, on solar cookers with photovoltaic energy, shows the total lack of power supply the cookers (thermal resistor) by solar batteries, equipped with a power system, adaptable to the needs of users. The heating power and temperature are very low and do not allow the cooking of daily dishes, during badly sunny days and at night.

This bibliography synthesis shows that solar cookers powered by solar batteries operate at a very low electrical power, and do not allow the desired heating and cooking. This is due to the low voltage of the batteries (12 V, 24 V), which directly feed the thermal resistances of the cookers [13,22,24]. This results in a very low maximum cooking temperature (below 80 °C) and a very long cooking time (over 105 min) [13,14]. On the market, there are AC cookers powered by photovoltaic panels and a DC/AC inverter, of high power (over 2 kW) connected to the AC electrical grid (hybrid inverter) [18]. The cost of this installation is very excessive and cannot be realized by the inhabitants not connected to the grid (rural world, isolated area, ...). In addition, for these installations, the absence of electrical energy from the grid causes the solar cookers to stop working completely, even on sunny days.

In order to remedy this installation problem and to overcome the problem of powering the cookers (or other applications) by the batteries, we propose a simple system that uses a DC/DC converter of the Boost type, dimensioned according to the cooking powers of the users. The operation of this converter is based on the user of power switches, controlled by PWM signals in a non-linear regime. It should be noted that in the case of use requiring important powers, important electric currents are delivered by the batteries. In order to protect the power switches from these high currents, we propose the use of several branches at the input of the DC/DC converter. Each branch is formed by an inductor and a power switch. The system realized during this work is controlled by programmable digital electronic cards. We have chosen and programmed digital components to ensure optimal operation of the cookers, taking into account any malfunctions (overvoltages and overcurrents).

In this contribution, in order to improve the performance of the cookers powered by photovoltaic energy and ensure their operation adapted to the users' needs (days and nights), the design and realization of a 300 W cooker (hot plate and box oven) are proposed. The innovative cooker is supplied by a battery (24 V, 520 Ah) through a DC/DC converter consisting of three interleaved boost converter cells the whole system is also equipped with an electronic control block. It should be noted that the operation and performance of the system depend only on the charge of the battery. So, it is independent of weather variations and the absence of the sun. The remainder of this paper is organized as follows. First, we present the structure and operation of the proposed cooker system. Second, the time-waveforms of the main electrical quantities (voltage, current, and power) of the DC/DC boost converter are analyzed for the given PWM duty cycles applied to the three cells. For both types of cookers (hot plates and box ovens), particular attention will be paid to: 1) maximizing the power transfer from the battery to the thermal resistor; 2) assessing the efficiency of the system, and 3) validation of the proposed solution for some typical applications, namely water heating and cooking food (fries and bread).

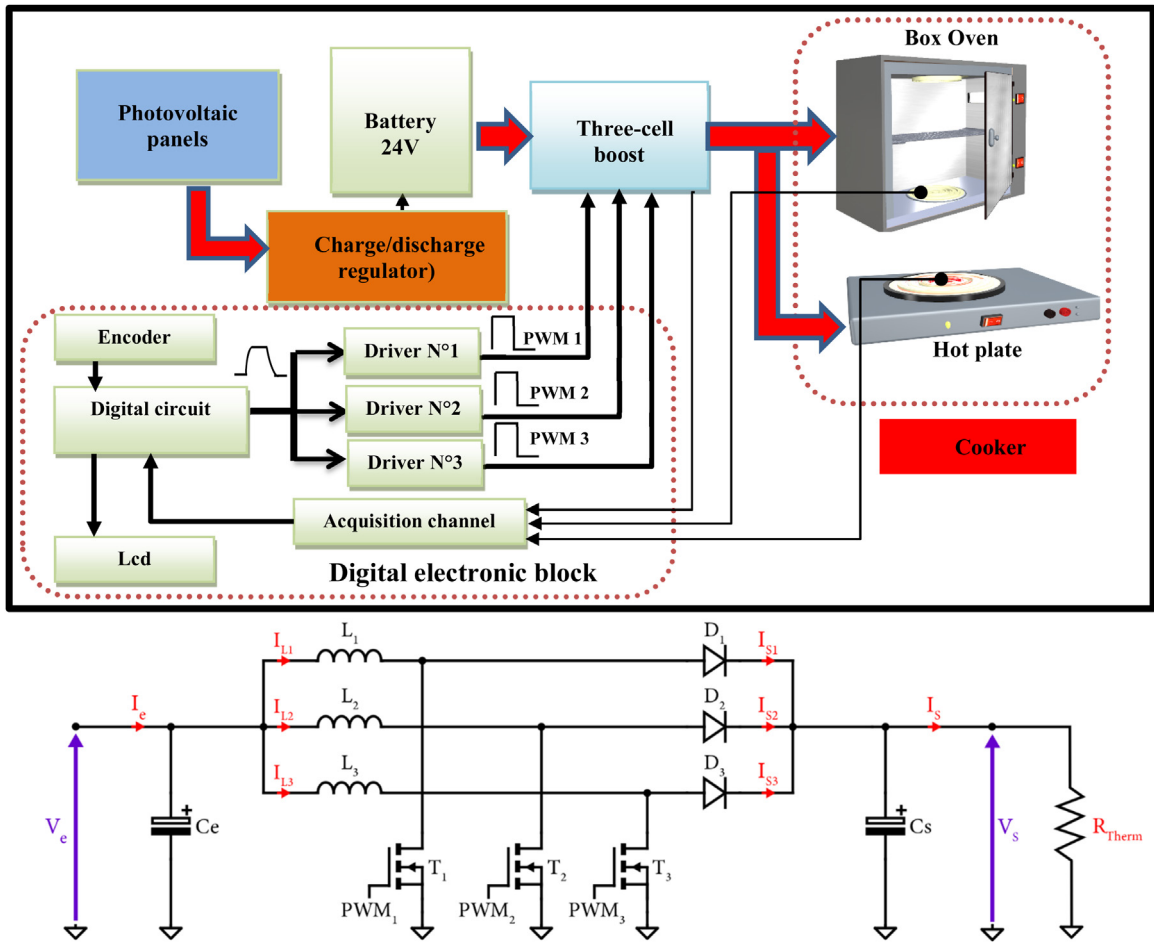

Fig. 1. Synoptic diagram of the cooker (Hot plate and oven box) and electrical circuit diagram of the three cell DC/DC boost converter, powered by a battery. (For interpretation of the references to colour in this figure legend, the reader is referred to the web version of this article.)

Structure and operation of the solar cooker powered by a battery

Fig. 1 shows the synoptic diagram of the proposed cooker system powered by a battery and the electrical circuit diagram of the power block equipped with the control circuit. This system is designed for a power level within the range of 300 - 400 W with a view to heating thermal resistors at a temperature as high as 1000 °C. The different blocks of this system are:

- ✓ Photovoltaic panels of 400 W peak provide the electrical energy and store it in the battery via a charge/discharge regulator.
- ✓ A 24 V/520 Ah battery that provides electrical energy to the cooker system.
- ✓ A DC/DC converter consists of three interleaved boost converter cells. The power switches are controlled by a digital electronic block generating three identical PWM signals. The form of these PWM signals is improved on the rising and falling edge by three drivers. Each cell of the DC/DC converter is formed by an inductor, a switch, and a diode. This structure makes it possible to limit the currents that circulate in the inductors following the strong currents flowing by the battery. The inductors are sized with $L_1 = L_2 = L_3 = 100 \mu\text{H}$ so that the converter operates in continuous-conduction mode under the given specifications, i.e. an output power of 400 W, a switching frequency of 20 kHz, a 24 V input voltage, and 75 V output voltage. Hence, the maximum value of the average output current is equal to 5.33 A. The ripple of the currents of the inductors Δi_L is not exceeding 5 A [18–21]. Note also that the input and output capacitors in the converter are selected to be $C_e = 1000 \mu\text{F}$ and $C_s = 1000 \mu\text{F}$, respectively.
- ✓ An electronic block formed by a digital circuit (Raspberry Pi Pico) [32] generates three identical PWM signals to control the power switches (T1, T2, T3), of the three boost converter cells, in switching mode. This digital circuit is equipped with analog and digital components, passive and active, in order to carry out the acquisition of the electrical (voltages, currents, and powers) and thermal quantities (temperatures of the cooker thermal resistor). All the measured quantities

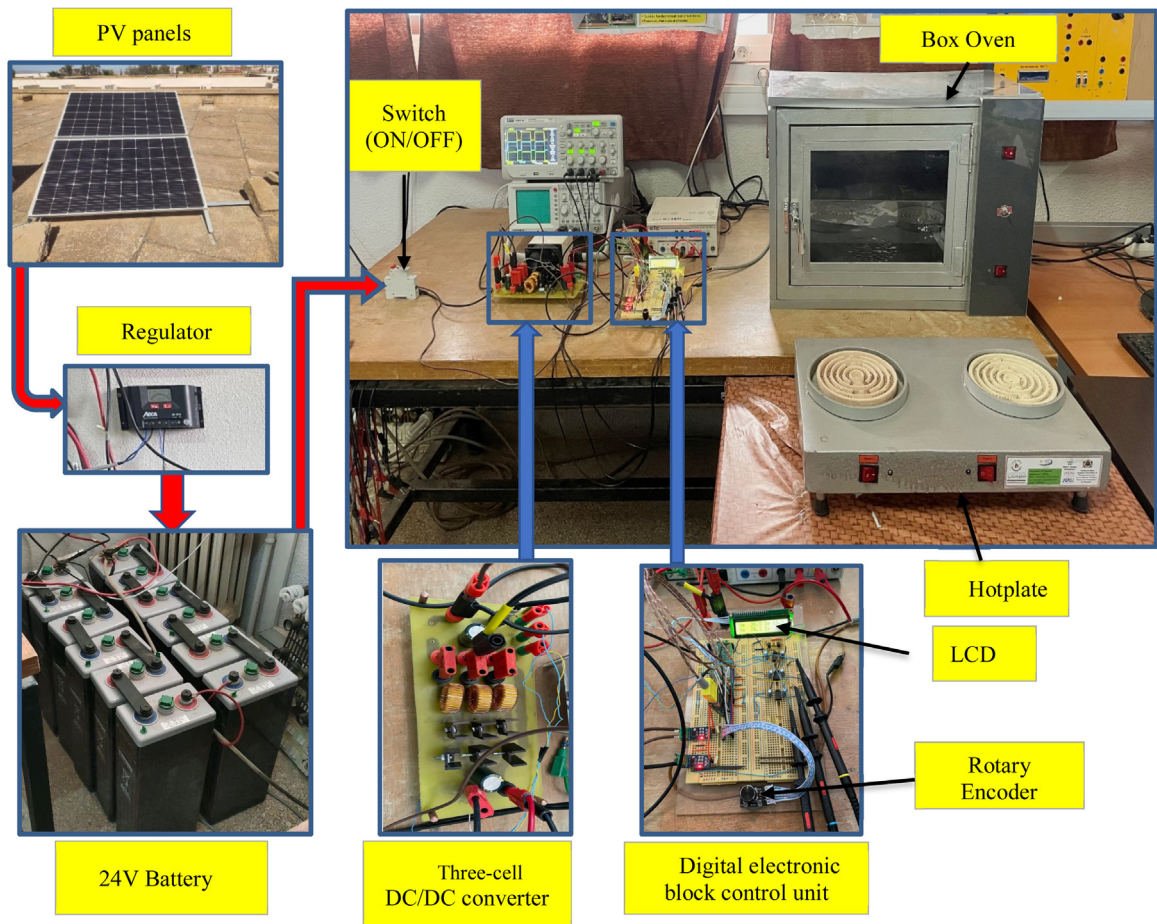

Fig. 2. Automated measurement bench set up in the laboratory.

are displayed on an LCD display by playing on a rotary encoder. The digital and analog (active) components are polarized by voltages 3.3 V and +12 V, from the battery.

- ✓ Hot plate and Oven Box heated by a thermal resistor placed in a ceramic, designed to withstand a temperature of 1400 °C and a power of 600 W.

Experimental results and discussion

Measurement bench

The measurement bench set up during this work is shown in Fig. 2. It is composed of the equipment necessary to experiment with the proposed cooker system (Fig. 1):

- Photovoltaic panels of 400 W peak, whose role is to provide electrical energy and store it in the battery via a charge/discharge regulator.
- An open lead type battery (520 Ah, 24 V) intended to supply the DC/DC boost converters with a 24 V DC input voltage and an input current of a maximum of 30 A. These values are consistent with the characteristics of the thermal resistor R_{Therm} used to conceive the cookers.
- A digital oscilloscope HPS40 to visualize all the electrical quantities in the proposed system,
- The cooker (i.e. the load of the system) consists of a hot plate or oven box suitable for daily cooking by users. It comprises a 600 W thermal resistor ($R_{Therm} = 15 \Omega$) of maximum temperature equal to 1000 °C [23]. In the case of the box oven, the battery feeds either a thermal resistor placed at the bottom of the oven or a resistor mounted at the top of the oven.
- The three-cell DC/DC boost converter (see Fig. 1), whose role is to match the operation of the battery to the load, according to the common duty cycle α of the switch PWM control signals. Note that here, considering the power level of the application, MOSFETs are used as power switches [18–21]. The converter is designed to operate at the frequency of 20 kHz, maximum power of 600 W, and average input current of 25 A. As already mentioned, the ripple of the current

in the inductors Δi_n is less than 5 A. Moreover, the ripple in the input and output voltages (denoted ΔV_e and ΔV_s) do not exceed 1 V and 2 V, respectively.

The governing equations of the three-cell boost DC/DC converter can be expressed as follows [20,25]:

$$\frac{V_s}{V_e} = \frac{1}{1 - \alpha} \quad (1)$$

$$\frac{I_{Si}}{I_{Li}} = (1 - \alpha) \quad (2)$$

$$\Delta i_{Li} = \frac{\alpha \cdot V_e}{L \cdot f} \quad (3)$$

$$\Delta V_s = \frac{I_s - (0,5 - \alpha)}{C_s \cdot f} = \frac{V_s - (0,5 - \alpha)}{(1 - \alpha) \cdot R_{Therm} \cdot C_s \cdot f} \quad (4)$$

Moreover, since:

$$I_{Bat} = I_{L1} + I_{L2} + I_{L3} = 3I_{Li} \text{ and } I_{Bat} = \frac{V_{Bat}}{R_{Bat}} \quad (5)$$

we also have

$$I_{Bat} = 3 \frac{I_{Si}}{(1 - \alpha)} \quad (6)$$

$$I_s = I_{Bat} (1 - \alpha) \quad (7)$$

$$R_{Bat} = (1 - \alpha)^2 R_{Thermique} \quad (8)$$

- An electronic block, formed by a digital circuit (Raspberry Pico) and active and passive components, which generates the PWM signals to control the DC/DC boost converter, in switching mode. This block is programmed to carry out the acquisition of all electrical (voltages, currents, and powers) and thermal (temperature of thermal and cooking resistor) quantities. All digital and analog (active) components are polarized by DC voltages +12 V, +3.3 V, and +5 V, using a dedicated card realized during this work and powered by the battery.
- Switches (ON/OFF) to power the system.

The cost of the complete autonomous cooker proposed in this work depends on the costs of the batteries, the photovoltaic panels which charge these batteries, and the electronic control block. A preliminary economic study has shown us the overall cost of our system is clearly interesting compared to the efficient thermal solar cooker operating on the son of the sun [17,28]. A more in-depth study on high-power systems (1.2 kW) is in progress.

Operation of the three-cell DC/DC boost converter

In order to validate the operation of the DC/DC converter, experimental measurements are carried out on the system shown in Fig. 2. The typical waveforms are depicted in Figs. 3 and 4 for each cell of the converter: the PWM signals with a duty cycle $\alpha=0.7$, the voltages across the power devices (MOSFETs and diodes), the voltage across each inductor, as well as the battery voltage and the voltage at the output of the converter. These results show:

- ✓ Identical PWM signals for controlling each switch (PWM1, PWM 2, and PWM 3), with a frequency of 20 kHz and an amplitude of 12 V. The shape and amplitude of the signals are consistent to control the power switches (MOSFETs) of the boost converter in nonlinear regime [18–21].
- ✓ When the PWM signals are in the high state (+12 V), the switches behave like short circuits ($V_{DS} = 0$ V ideally), and the current flowing through each inductor increases (under the applied voltage $V_L = V_{bat} = 24$ V). During that operating sequence, the diodes are blocked ($V_D = V_s = -70$ V),
- ✓ When the PWM signals are in the low state (0 V), the switches behave like open circuits ($V_{DS} = V_s = 75$ V), and the inductor currents decrease (under $V_L = V_{bat} - V_s = -46$ V). During this sequence, the diodes are conducting ($V_D = 0$ V ideally),
- ✓ The battery voltage and the voltage at the output of the converter reach the average values $V_{bat} = 24$ V and $V_s = 75$ V (Fig. 3). Moreover, due to the smoothing effect of the capacitors (C_e and C_s), the ripples in the corresponding voltages are equal to 1 V and 2 V, respectively.
- ✓ At the given power (400 W), the average current flowing through each inductor is approximately 5.3 A, with a ripple of 5 A.

Note that the comparison of these results with simulations conducted in Orcad-Pspice has shown a very good agreement. Moreover, the efficiency of the DC/DC converter is 90%. From the above, it can be concluded the proper operation of the three-cell DC/DC boost converter conceived in this work (Fig. 2).

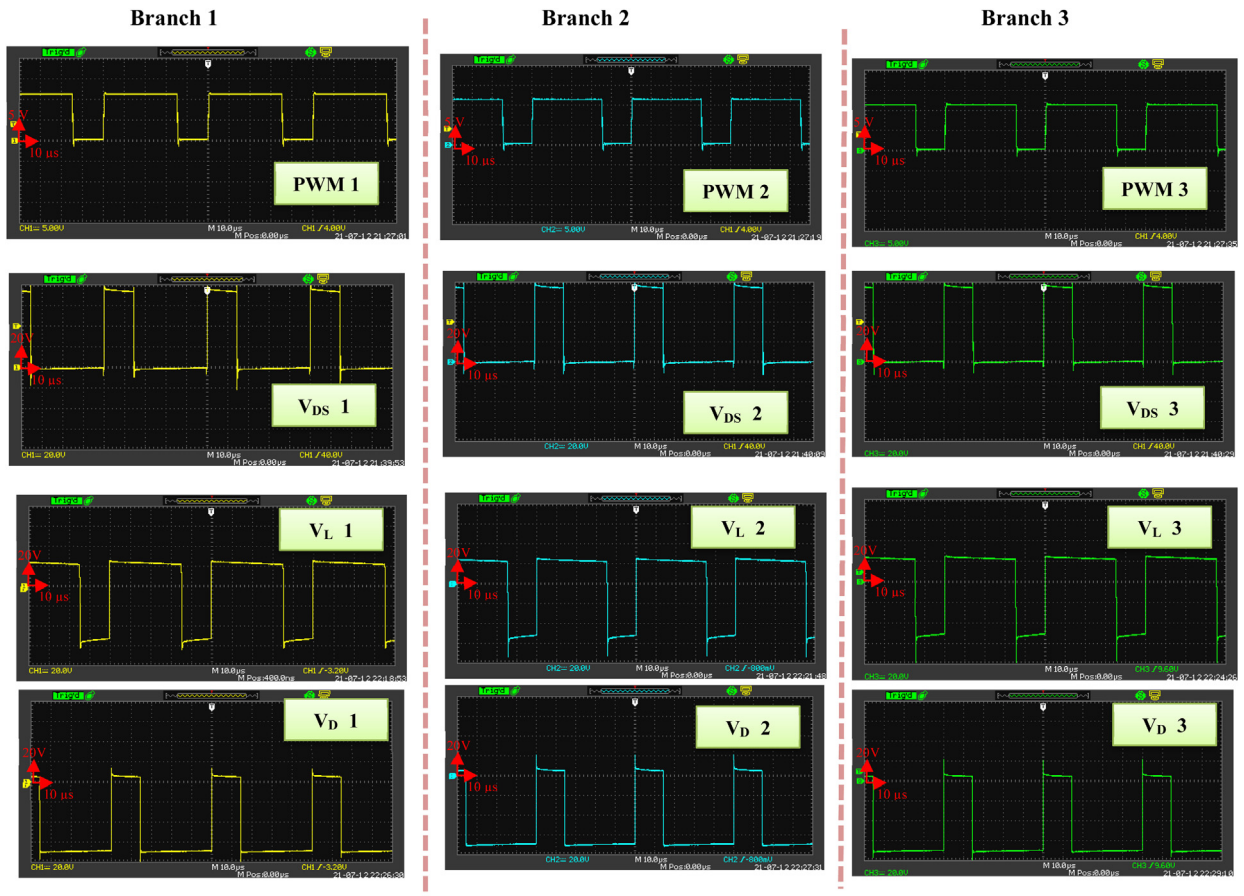

Fig. 3. Typical waveforms of the main electrical quantities in each cell of the DC/DC converter in Fig. 1, for $\alpha = 0.7$.

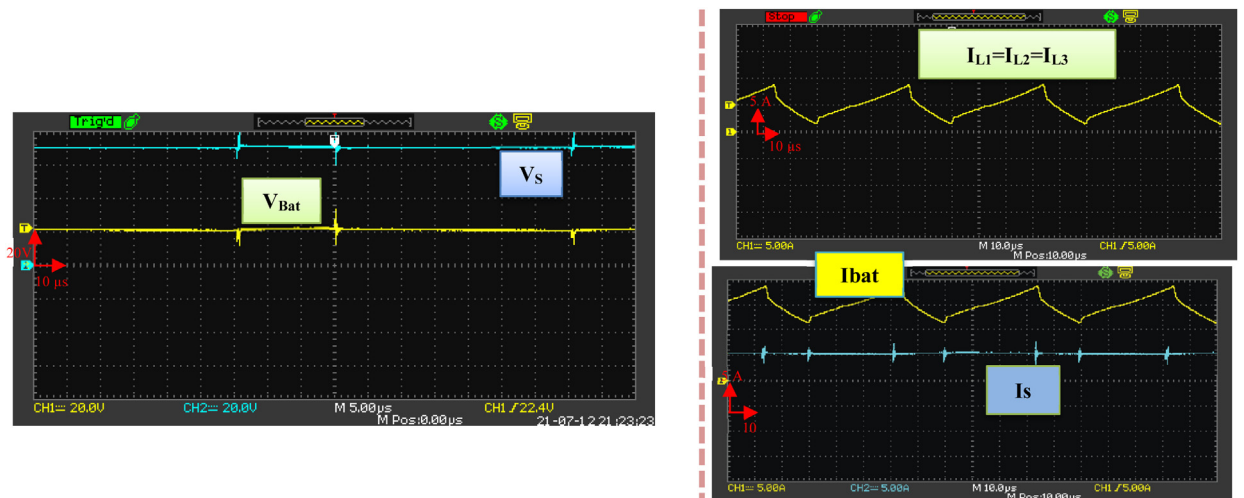

Fig. 4. Typical waveforms of the battery voltage and current and output electrical quantities, as well as the currents flowing through in the inductors (I_{L1} , I_{L2} and I_{L3}), for a duty cycle of $\alpha = 0.7$.

Operation of the hot plate cooker supplied by the battery

In order to prove the feasibility and reliability of the 'Hot plate' cooker (Fig. 1) developed during this work, experimental tests are first conducted on the prototype shown in Fig. 2. The considered scenarios are:

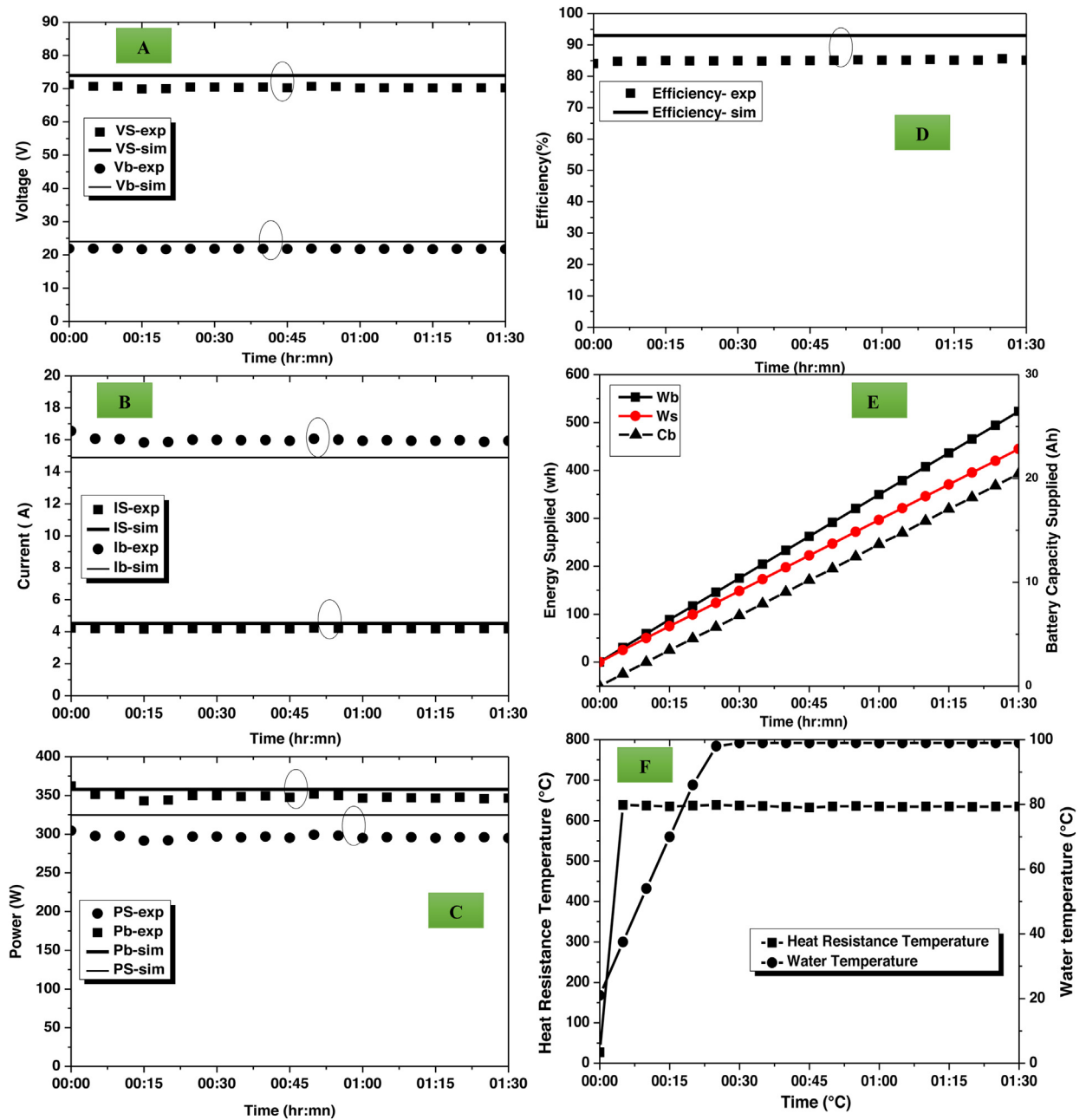

Fig. 5. Electrical quantities, experimental and simulated (A to D), at the input and at the output of the complete system, when heating one liter of water. A Input and output voltages; B Input and output currents; C Converter input and output power; D Efficiency of the converter; E Energy supplied by the battery, energy consumed by the thermal resistor while heating and capacity “consumed” by the battery; F Temperature of the thermal resistors and water.

- Heating one liter of water until boiling,
- Cooking food (here 1 kg of fries) at high temperature (typically above 120 °C).

We chose these two applications to experiment with our system in two situations requiring medium (100–140 °C) and high (> 200 °C) cooking temperatures. These situations correspond to the daily lifestyles of the beneficiaries, in the rural and urban world. For each experiment, the electrical quantities (voltage, current, power) at the input and output of the DC/DC converter are recorded as well as the electrical heating energies, electrical energy supplied by the battery, the DC/DC converter efficiency, the temperatures of the thermal resistor and that of the water and oil is heated. For the voltages, currents, powers, and efficiencies, the theoretical results (obtained according to Eqs. (1) to 6) are also reported on the graphs.

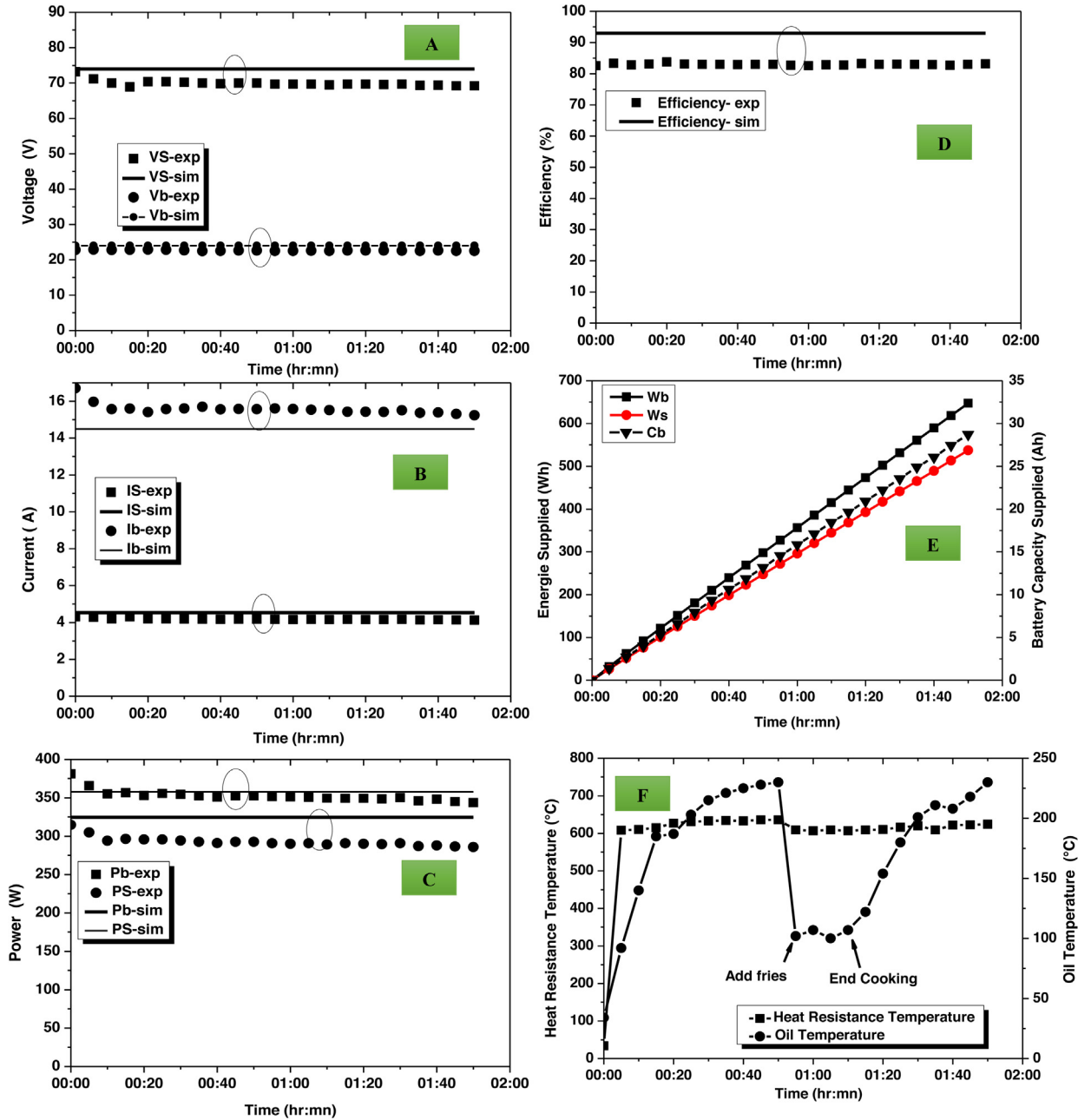

Fig. 6. Electrical quantities, experimental and simulated (A to D), at the input and at the output of the complete system, in the case of cooking 1 kg of fries. A Input and output voltages; B Input and output currents; C Converter input and output power; D Efficiency of the converter; E Energy supplied by the batteries, energy consumed by the thermal resistor while cooking and battery capacity “consumed”; F Temperature of the thermal resistors and oil.

It should be noted that as concerns heating one liter of water, we deduced the heating efficiency η of the proposed cooker [4,8]. This is done by estimating, for an electrical output power PS of the DC/DC converter, the sensible output power P_0 of heating of water of mass m_w from the increase in water temperature ΔT , during a period Δt . The power P_0 and the thermal efficiency η was calculated using the following expressions:

$$P_0 = \frac{m_w \times Cp \times \Delta T}{\Delta t} \tag{9}$$

$$\eta = \frac{P_0}{PS} \tag{10}$$



Fig. 7. Cooking food (fries) using the hot plate of Fig. 2.

$$= \frac{m_w \times C_p \times \Delta T}{P_s \cdot \Delta t} \quad (11)$$

Where:

C_p : Specific heat capacity of water at constant pressure (4.18 kJ/kg. °C).

Water heating

The typical results obtained when heating one liter of water are shown in Fig. 5. It can be observed that the DC voltages and currents of the converter are worth respectively 21.8 V and 16 A at the input, and 70.5 V and 4.22 A at the output. The input and output power of the converter is 350 W and 298 W respectively, corresponding to an efficiency of 85%.

The temperature of the thermal resistor reaches the value of 200 °C after 5 s of heating (i.e. a temperature rises of 40 °C/s) and the maximum value of 640 °C after 20 s. During 5 min of heating, the water temperature varies from 21 °C to 37.5 °C, with a thermal efficiency estimated to be 77% and the water reaches the boiling temperature of 99 °C after 25 min of heating. The electrical energy supplied by the battery and the energy available for heating is 523 Wh and 444.6 Wh, respectively which is a capacity of 20.4 Ah of the battery “consumed” (i.e. about 4% of the capacity of the battery when fully charged)

These results obtained show a very good agreement between the experimental results and simulation. Comparing these results with those obtained on conventional thermal ovens [4,33-35,37], it can be concluded that the innovative cooker proposed in this work has good energy performance: reduction in water heating time by 25% and improvement of the thermal efficiency by 77%. For the considered experiment, this clearly demonstrates the feasibility of the operation of the hot plate powered by the solar battery and using the above-described power block with PWM control.

Cooking food (Fries)

In Fig. 6, the typical results obtained in the case of cooking 1 kg of fries by the electrical energy supplied from the battery are presented. It can be observed that the DC voltages and currents of the converter are respectively 22.5 V and 15.6 A at the input, and 70 V and 4.21 A at the output. The input and output power of the converter are respectively of the order of 351 W and 295 W, i.e. efficiency of 84%. The oil temperature reaches 100 °C after 6 min of heating, that is a temperature rise of 16.67 °C / min with a maximum temperature of the heating resistor and that of oil are respectively of the order of 640 °C and 230 °C. When adding 1 kg of fries, the oil temperature decreases temporarily to 102 °C. Then, it increases again gradually while cooking to reach 230 °C, after 15 min.

The energy provided by the battery and the energy used during a time of 20 min of cooking are respectively of the order of 647.36 Wh and 537.23 Wh, i.e. consumption of 1.34% and 1.47% of the total energy supplied by the battery. The “consumed” capacity of the battery is about 28.72 Ah, which corresponds to 5.52% of the capacity of the battery when fully charged).

The comparison of these results with those available in the literature for traditional cookers devoid of thermal and electrical storage (thermal box ovens, heating plates with photovoltaic panels) [16,17,26,29,31,36] shows remarkable performances. These are comparable to the results in literature when the cookers (heating plates) are supplied by photovoltaic panels [16]. It can therefore be concluded to the proper operation of the cooker shown is in Fig. 2, especially for cooking at high temperatures (>120 °C) (Fig. 7).

Operation of the oven box cooker by solar batteries

In order to show the feasibility and reliability of the 'Box oven' cooker (Fig. 1) developed during this work, the prototype shown in Fig. 2 is also tested according to the following two scenarios:

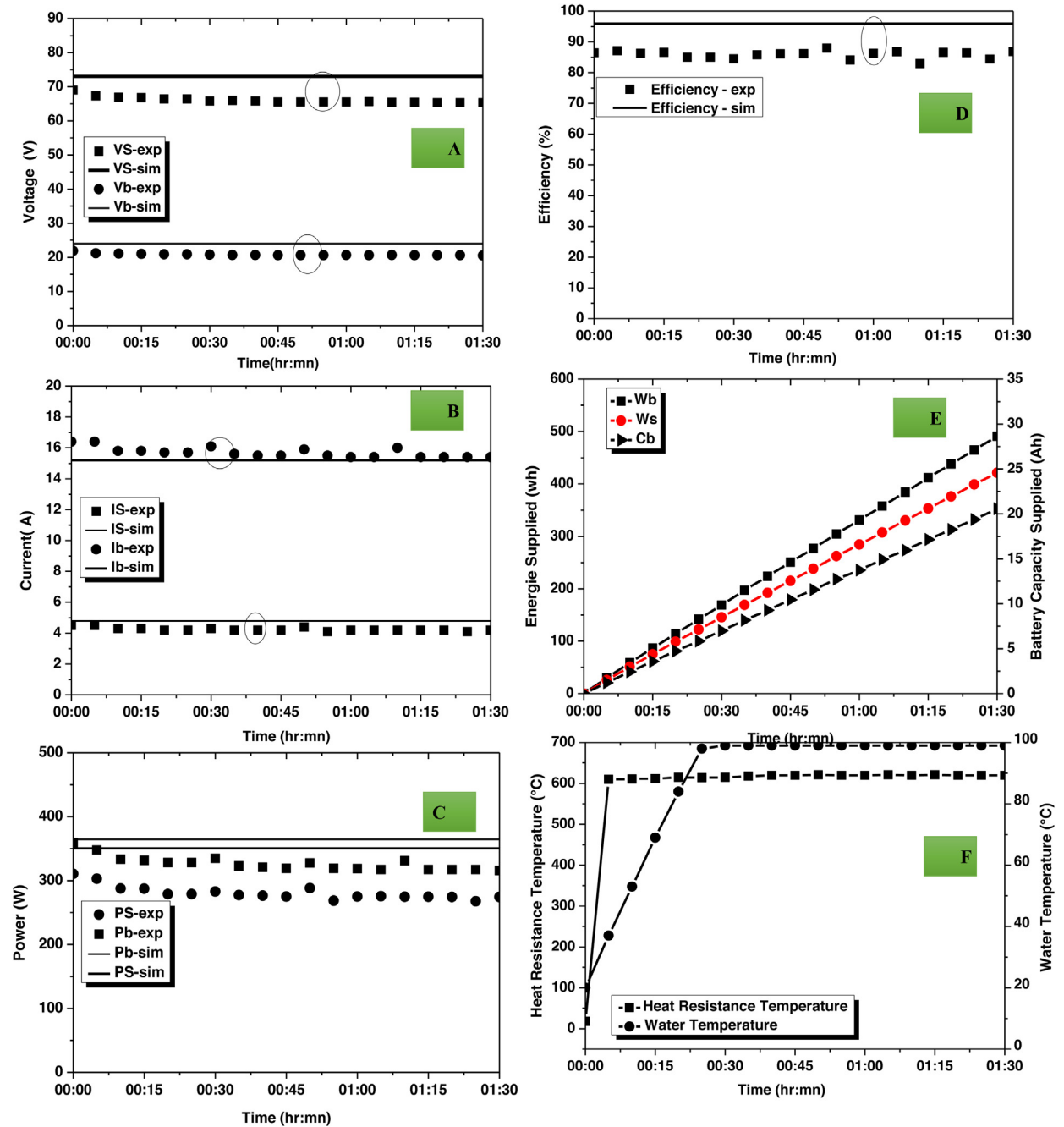

Fig. 8. Electrical quantities, experimental and simulated (A to D), at the input and at the output of the complete system, when heating 1 liter of water. A Input and output voltages; B Input and output currents; C Converter input and output power; D Efficiency of the converter; E Energy supplied by the batteries, energy consumed by the thermal resistor during heating and “consumed” capacity of the battery; F Temperature of the thermal resistor and water.

- Heating one liter of water until boiling,
- Baking bread at temperatures above 100 °C.

For each scenario, an acquisition of the main quantities of interest is performed. These are the electrical quantities (voltage, current, power) at the input and output terminals of the DC/DC converter, the heating energy, the electrical energy supplied by the battery, the efficiency of the DC/DC converter, as well as the temperatures of the thermal resistor, heated water and on the interior of the oven.

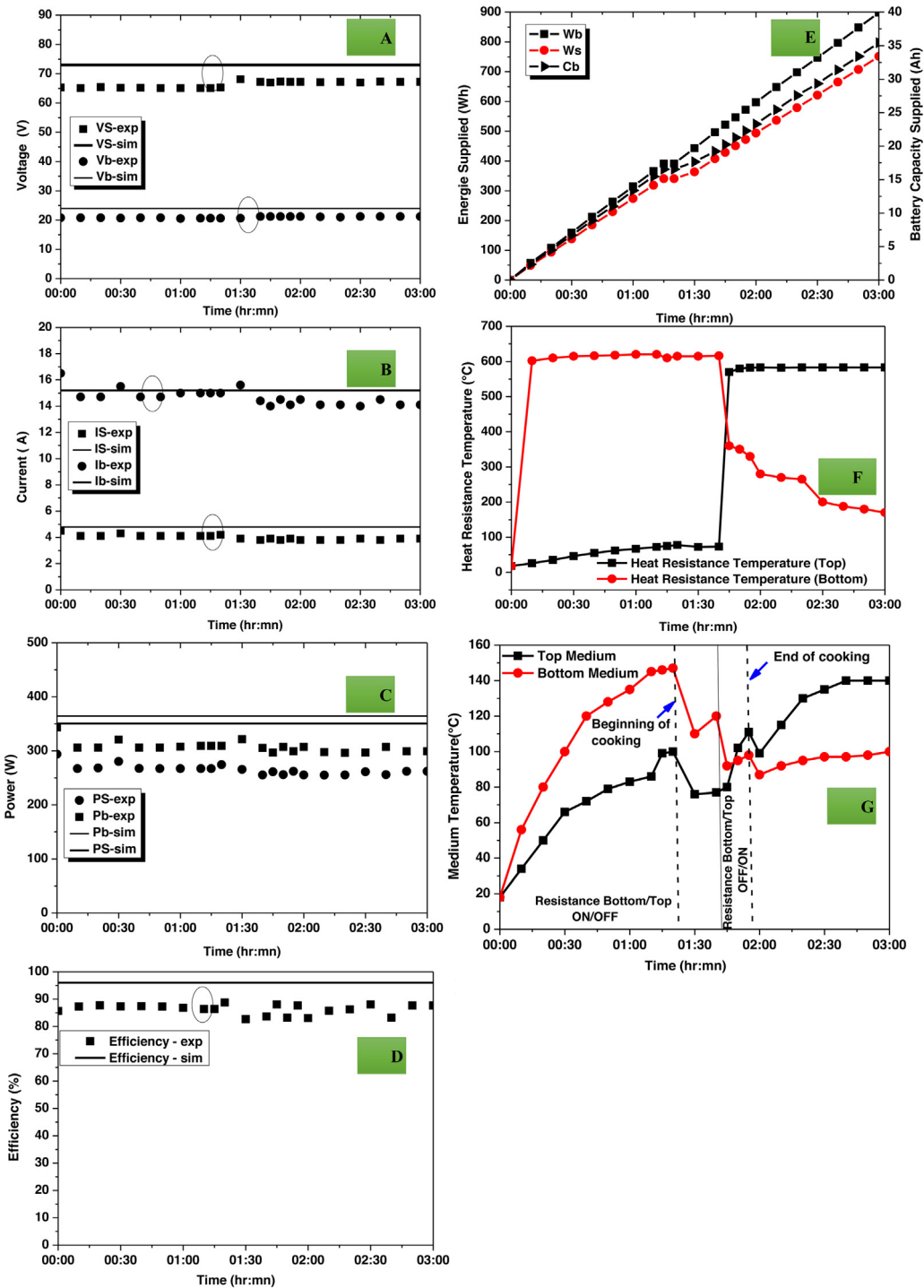

Fig. 9. Electrical quantities, experimental and simulated (A to D), at the input and output of the complete system, in the case of baking 1 kg of bread. A Input and output voltage; B Current at the input and at the output; C Converter input and output power; D Efficiency of the converter; E Energy supplied by the batteries, energy consumed by the thermal resistor during heating and “consumed” capacity of the battery; F Temperature of the thermal resistors (top and bottom); G temperature of the medium (top and bottom).

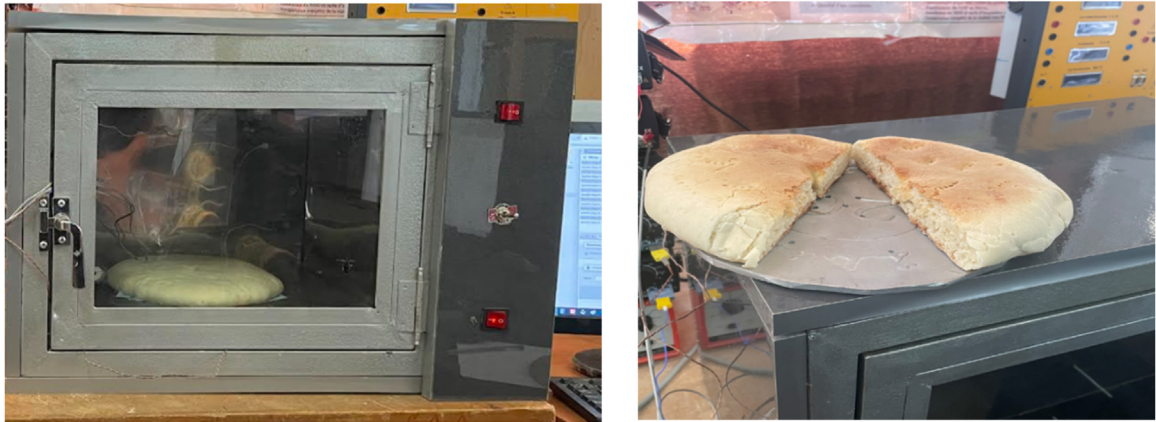

Fig. 10. Baking bread in the oven box in Fig. 2.

Water heating

Under the same conditions as in paragraph III. 3. 1, the box oven is first used to heat one liter of water. It can be observed that the voltage and current at the input of the converter are respectively 20.6 V and 15 A, at the output are of the order of 65.1 V and 4.1A, which correspond to the power at the input and output of the converter of 309 W and 266.91 W respectively, i.e. efficiency of 86%.

During 5 min of heating, the water temperature varies from 20 °C to 37 °C (which corresponds to a heating rate of 3.4 °C/min) with a thermal efficiency estimated to be 78%. The energy supplied by the batteries and that for heating is of the order of 597.27 Wh and 493.96 Wh each, i.e., 4.78% and 3.95% of the total energy stored by the battery. The capacity of the battery "consumed" during heating is of the order of 23.3 Ah (i.e. 4.4% of the capacity of the fully charged battery).

All the above results show similar performance to the results obtained with the heating plate, and even better performances compared to conventional box ovens [16,17,26,29,31,36]. We can thus conclude the proper operation of the box oven supplied by the batteries and using the power block with the electrical control circuit designed in this work.

Baking bread

Finally, the solar oven in Fig. 2 is used for the application of baking bread (1 kg). The measurements include the electrical quantities at the input and output terminals of the converter, the temperature inside the oven, and the temperature of the thermal resistor. It can be observed that the voltage and current at the input of the converter are of the order of 20.6 V and 15 A respectively. The corresponding DC voltage and current measured at the output are 65.1 V and 4.1A which is the input and output power of the converter of the order of 309 W and 266.91 W (i.e. efficiency of 86%).

The maximum temperature of the heating resistor and that of the medium are respectively of the order of 620 °C and 147 °C with a temperature of the oven reaching 100 °C after 30 min of heating (i.e. a heating rate of 3.33 °C/min). When adding bread, the temperature of the oven decreases to the value of 102 °C. Then, it increases again gradually while cooking to reach the final temperature of 140 °C.

The energy supplied by the battery and that available for heating are respectively of the order of 597.27 Wh and 493.96 Wh (i.e., 4.78% and 3.95% of the total energy stored by the battery) with the capacity of the battery "consumed" during 30 min of the cooking time is about of 23.3 Ah (i.e. about 4.4% of the battery capacity when fully charged).

The above results show performance practically comparable to classical cooking with wood [37, 38] or gas [38, 39]. These performances and the low consumption of electrical energy while cooking (< 5%) demonstrate the feasibility of the box ovens (Fig. 2), powered by solar batteries, for cooking bread. This system could be applied to other daily cooking (vegetables, meats, etc.).

Conclusion

In this paper, we have shown the feasibility of the operation of a cooking system (hot plate and box oven) supplied by solar batteries (24 V, 520 AH). The batteries are charged by the photovoltaic panels (600 W peak), and the cooker is formed either by a hot plate or a box oven. The heating of the cooker is carried out by these solar batteries that power a three-cell DC/DC boost converter (equipped with a numerical control that generates the PWM signals at the frequency of 20 kHz and a duty cycle of 0.7) and a thermal resistor of 15 Ω.

Experimental tests conducted on this cooker have shown that the temperatures reached while heating one liter of water or cooking food (Fries and bread) are 99 °C and 150 °C, respectively, after 25 min and 30 min. The efficiency of the conceived converter is 90% and the thermal efficiency is about 78%. Moreover, the heating or cooking time is of the order of 30 min and the energy consumed for cooking is less than 5% of the total energy stored in the batteries (when fully charged); These

results demonstrate the proper operation of the DC/DC converter and its numerical control, and the global cooker (hot plates and box ovens) designed during work.

Declaration of Competing Interest

The authors declare that they have no known competing financial interests or personal relationships that could have appeared to influence the work reported in this paper.

Acknowledgements

This research is supported within the framework of the projects: Morocco-Wallonie Brussels Cooperation Program (2018–2022), Wallonie-Bruxelles-International (WBI) (Belgium), project 4, n°2, Solar Indoor Cooking Systems of the Next Generation SoCoNexGen project (2022–2025) is part of the Long-term Europe Africa Partnership on Renewable Energy LEAP-RE programme. LEAP-RE has received funding from the European Union's Horizon 2020 Research and Innovation Program under Grant Agreement 963530. National Initiative for Human Development INDH, Berkane Province, Morocco, project 2017//29.

References

- [1] Shyam S. Nandwani, Solar cookers-cheap technology with high ecological benefits, *Ecol. Econ.* 17 (2) (1996) 73–81.
- [2] Hilde M. TOONEN, Adapting to an innovation: solar cooking in the urban households of Ouagadougou (Burkina Faso), *Phys. Chem. Earth, Parts A/B/C* 34 (1–2) (2009) 65–71.
- [3] Jose M. Arenas, Design, development and testing of a portable parabolic solar kitchen, *Renew. Energy* 32 (2) (2007) 257–266.
- [4] Klemens Schwarzer, Maria Eugenia Vieira Da Silva, Solar cooking system with or without heat storage for families and institutions, *Sol. Energy* 75 (1) (2003) 35–41.
- [5] Fatima Yettou, B. Azoui, A. Malek, et al., Solar cooker realizations in actual use: an overview, *Renew. Sustain. Energy Rev.* 37 (2014) 288–306.
- [6] R.M. Muthusivagami, R. Velraj, R. Sethumadhavan, Solar cookers with and without thermal storage—a review, *Renew. Sustain. Energy Rev.* 14 (2) (2010) 691–701.
- [7] N.L. Panwar, S.C. Kaushik, Surendra Et Kothari, Role of renewable energy sources in environmental protection: a review, *Renew. Sustain. Energy Rev.* 15 (3) (2011) 1513–1524.
- [8] Klemens Schwarzer, Maria Eugenia Vieira Da Silva, Characterisation and design methods of solar cookers, *Sol. Energy* 82 (2) (2008) 157–163.
- [9] Simon Batchelor, Ed Brown, Jon Leary, et al., Solar electric cooking in Africa: where will the transition happen first, *Energy Res. Social Sci.* 40 (2018) 257–272.
- [10] Suhail Zaki Farooqui, A gravity-based tracking system for box type solar cookers, *Sol. Energy* 92 (2013) 62–68.
- [11] B.Z. Adewole, O.T. Popoola, A.A. Asere, et al., Thermal performance of a reflector based solar box cooker implemented in Ile-Ife, Nigeria, *Int. J. Energy Engin.* 5 (5) (2015) 95–101.
- [12] Emmanuel Yeboah Osei, Araba AMO-AIDOO, Design, fabrication, and testing of a solar photovoltaic cooker in Ghana, in: *International Conference on Applied Science and Technology Conference Proceedings*, 2018, pp. 182–188.
- [13] Smita B. Joshi, A.R. Jani, Design, development and testing of a small-scale hybrid solar cooker, *Sol. Energy* 122 (2015) 148–155.
- [14] Smita B. Joshi, A.R. JANI, Photovoltaic and thermal hybridized solar cooker, *ISRN Renew. Energy* 2013 (2013).
- [15] ATTYAOUL, Slimen, ALL, Chaouki, RABHI, Kamel, Nasri, F., & Bacha, H.B. Experimental investigation and modelling of a PV/T solar cooker. corrosion detection in T-bend oil pipelines based on fuzzy implementation, 2012, p. 1632.
- [16] I. Atmane, N. EL moussaoui, K. Kassmi, O. Deblecker, N. Bachiri, Development of an innovative cooker (hot plate) with photovoltaic solar energy, *J. Energy Storage* 36 (2021) 102399.
- [17] Nouredine EL moussaoui, Sofian Talbi, Ilyas Atmane, K. Kassmi, K. Schwarzer, H. Chayeb, N. Bachiri, Feasibility of a new design of a parabolic trough solar thermal cooker (PSTC), *Sol. Energy* 201 (2020) 866–871.
- [18] P.R. Rivera, M.L. McIntyre, M. Mohebbi, J. Latham, « Nonlinear control for single-stage single-phase grid-connected photovoltaic systems », *IEEE, Workshop on Control and Modeling for Power Electronics IEEE, 2017:1-7*. JfJ van Rensburg, MJ Case2, DV Nicolae, « Double-Boost DC to DC Converter », *Industrial Electronics, 2008 IECON 2008. 34th Annual Conference of IEEE4*.
- [19] Hsiu-Hao Liang, Tsorng-Juu Liang, Senior Member, IEEE, Kai-Hui Chen and Shih- Ming Chen, « Anssa Bidirectional Double-Boost DC-DC Converter », *power electronics and drive systems (PEDS), 2013 IEEE 10th International Conference on*.
- [20] Lamkaddem Ali, Khalil kassmi, Design and realization of a new structure of DC/DC and DC/AC converters dedicated to renewable energies, *4th International Conference on Electrical and Information Technologies ICEIT'2020. IEEE Conference Publications, 2020*.
- [21] Salah K. Jawad, Investigation of the dimensions design components for the rectangular indirect resistance electrical furnaces, *Am. J. Engg. & Applied Sci.* 3 (2) (2010) 350–354.
- [22] Mitica Iustinian NEACA, Andreea Maria NEACA, et al., The modeling of the heating resistors in transient regime, *J. Mater. Sci. Engin. B* 1 (2) (2011) 170–177.
- [23] O. Ilias ATMANE, MOUSSAOUI EL, KASSMI Nouredine, Deblecker Khalil, N Bachiri, Alternating multi-stage maximum power point tracking controlled parallel photovoltaic systems for "solar cooker, *Int. J. Circuit Theory Appl.* (2021).
- [24] Al-Nimr MOH'D A, Wahib A. Al-ammari, et al., A novel hybrid PV-distillation system, *Sol. Energy* 135 (2016) 874–883.
- [25] Xuefeng Hu, I.E.E.E. Member, Penghui Ma, Jianzhang Wang, Guodong Tan, Zhilei Yao, A hybrid cascaded DC–DC boost converter with ripple reduction and large conversion ratio, *IEEE J. Emerg. Sel. Top Power Electron* Volume: 8 (Issue: 1) (2020) March.
- [26] N. El moussaoui, S. Talbi, K. Kassmi, K. Schwarzer, H. Chayeb, N. Bachiri, Cooking with a parabolic trough solar thermal cooker in a moroccan climate, in: *Sustainable Entrepreneurship, Renewable Energy-Based Projects, and Digitalization*, CRC Press, 2020, pp. 229–243.
- [27] Rohit MISRA, Tarun Kumar ASERI, Thermal performance enhancement of box-type solar cooker: a new approach, *Int. J. Sustainable Energy* 31 (2) (2012) 107–118.
- [28] S. ISLAM, S.B. AZAD, H. FAKIR, et al., Development of electric stove for the smart use of solar photovoltaic energy, in: *2014 IEEE Region 10 Humanitarian Technology Conference (R10 HTC)*, IEEE, 2014, pp. 94–98.
- [29] Boureima et Maurice Dianda, Thierry Sikoudouin, KY. parabolic trough cooker, *Int. J. Current Resear Key Words Vol.* 11 (Issue, 03) (2019) 1869–1874 March.
- [30] S. Das, S.S. Solomon, A. Saini, Thermal analysis of paraboloid dish type solar cooker, *J. Phys. Conf. Ser.* 1276 (1) (2019) IOP Publishing.
- [31] Atul G. BHAVE, K.A.L.E. et, K. Chirag, Development of a thermal storage type solar cooker for high temperature cooking using solar salt, *Sol. Energy Mater. Sol. Cells* 208 (2020) 110394.
- [32] Madhavan. Thothadri, An analysis on clock speeds in raspberry Pi Pico and Arduino Uno Microcontrollers, *American Journal of Engineering and Technology Management* 6 (3) (2021) 41–46.

- [33] M.E.V. Silva, L.L. Santana, A. Pinheiro, et al., Comparative Study of two Solar Cookers: parabolic Reflector and Flate Plate Collector Indirect Heating, Proceedings of Rio 5 (2005).
- [34] Da, Silva M, Schwarzer, et al. "Experimental results of a solar cooker with heat storage." Proceedings of Rio 02 world climate and energy event. 2002;89–93.
- [35] Ian. Edmonds, Low cost realisation of a high temperature solar cooker, Renew Energy 121 (2018) 94–101.
- [36] Arghya Saha, Fahmida Sultana, Md Asrarul Haque, et al., Design of MPPT mounted solar based double coil DC electric cooker with smart temperature control device, in: 2019 5th International Conference on Advances in Electrical Engineering (ICAEE), IEEE, 2019, pp. 212–217.
- [37] Washam, Cynthia. "Cooking with wood may fuel low birth weight: kitchen smoke puts babies at risk." (2008): A173–A173.
- [38] Babajide S. Kosemani, Adeyinka T. Ilori, Ayoade O. Atere, Modification and optimization of a baking oven for small scale bread production, Agricul. Sci. 12.6 (2021) 630–644.
- [39] Daniele Landi, et al., Comparative life cycle assessment of electric and gas ovens in the Italian context: an environmental and technical evaluation, J. Clean Prod. 221 (2019) 189–201.